

CA.10.05 GT NY

GT

. Slide - off Air Nippers Horizontal - Type GT NY

. Angusschneider-Einfahr-und Schneidefunktion GT NY

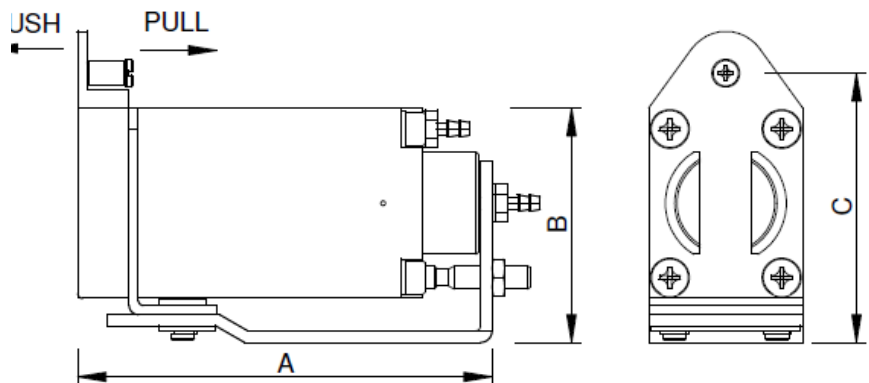
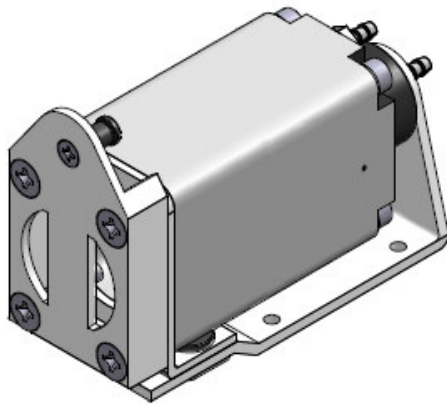

Remarks:

Two available models:
Push = .R
Pull

Units are not prearranged for using reversible blades.

On this kind of unit it's possible to adjust the blades opening from 3 mm to 7 mm

Bemerkungen:

Zwei Typen lieferbar:
Drücken = .R
Ziehen

Die Einheit passt nicht zu reversibelen Schneideinsätzen

Diese bestimmte Einheit erlaubt die Regelung der Öffnung der Schneideinsätze von 3 mm bis 7 mm

Article no. Artikelnr.			Cutting Capacity	A	B	C	Weight Gewicht
CA.10.05.001	GT-NY05	PULL	3.0	75.9	39.1	55.6	155 g
CA.10.05.001.R	GT-NY05R	PUSH					
CA.10.05.002	GT-NY10	PULL	3.5	82.1	44	59.6	210 g
CA.10.05.002.R	GT-NY10R	PUSH					
CA.10.05.003	GT-NY15	PULL	4.0	93	50.5	67	319 g
CA.10.05.003.R	GT-NY15R	PUSH					
CA.10.05.004	GT-NY25	PULL	5.0	108.5	58.5	78	580 g
CA.10.05.004.R	GT-NY25R	PUSH					

PULL TYPE

PUSH TYPE

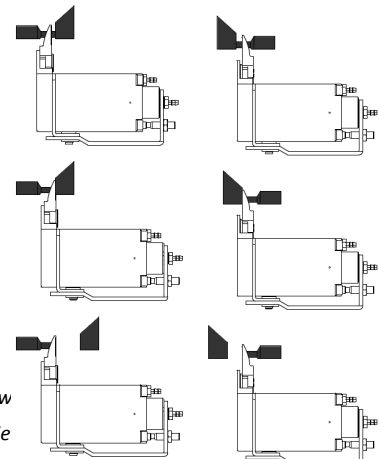

Application example / Anwendungsbeispiele

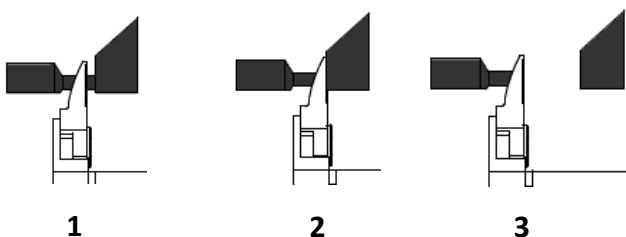

For more information and to check the drawings, please visit our w
Für weitere Informationen und Blick auf die Zeichnungen, bitte besuchen Sie

CA.10.07 GT NY
GT

. Blades GT NY

. Schneideinsätze GT NY

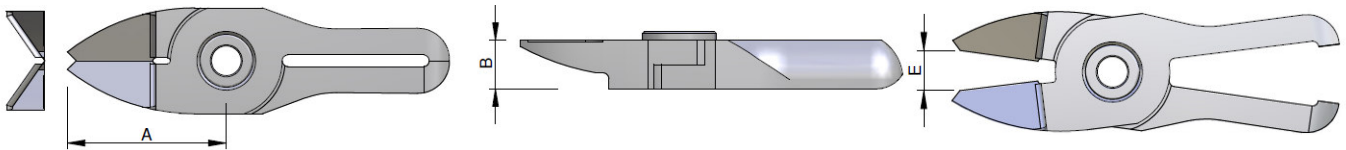
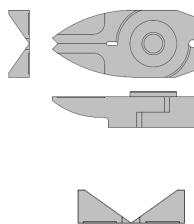
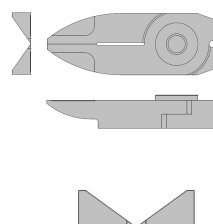
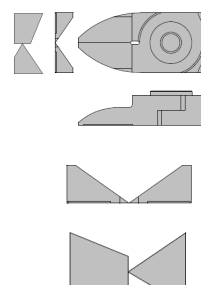
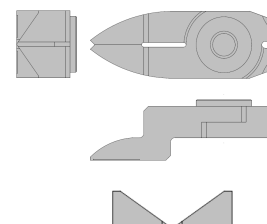

Table:

M = suitable for CA.10.05..

passend für CA.10.05..

Article no. Artikelnr.			Cutting capacity		M	A	B	E	Weight Gewicht
			Plastic	Plastic fiber					
CA.10.07.NY05AJ	Straight	PULL	3.0	2.0	GT-NY05	22	7	4	22 g
CA.10.07.NY05AJL	Straight Long	PULL	2.8	1.6		31	7	5.5	29 g
CA.10.07.NY05RAJ	Straight	PUSH	3.0	2.0	GT-NY05R	22	7	4	22 g
CA.10.07.NY05RAH	Crank	PUSH	3.0	2.0		30	12	5	31 g
CA.10.07.NY10AJ	straight	PULL	3.5	2.3	GT-NY10	24	7.2	6	28 g
CA.10.07.NY10AJL	Straight Long	PULL	3.2	2.1		33	7.2	8	37 g
CA.10.07.NY10RAJ	Straight	PUSH	3.5	2.3	GT-NY10R	24	7.2	6	28 g
CA.10.07.NY10RAH	Crank	PUSH	3.5	2.3		32	12.2	7	36 g
CA.10.07.NY15AJ	Straight	PULL	4.0	2.6	GT-NY15	27	8.2	8	41 g
CA.10.07.NY15AJL	Straight Long	PULL	3.7	2.3		38	8.2	11	50 g
CA.10.07.NY15RAJ	Straight	PUSH	4.0	2.6	GT-NY15R	27	8.2	8	41 g
CA.10.07.NY15RAH	Crank	PUSH	4.0	2.6		35	13.2	9	52 g
CA.10.07.NY25AJ	Straight	PULL	5.0	3.4	GT-NY25	31	10	9	65 g
CA.10.07.NY25AJL	Straight Long	PULL	4.7	3.0		46	10	13	88 g
CA.10.07.NY25RAJ	Straight	PUSH	5.0	3.4	GT-NY25R	31	10	9	65 g
CA.10.07.NY25RAH	Crank	PUSH	5.0	3.4		42	16	12	89 g

AJ

AJL

RBJ-RAJ

RAH

For more information and to check the drawings, please visit our website

Für weitere Informationen und Blick auf die Zeichnungen, bitte besuchen Sie unsere Website